

SPECIFICATION SHEET

MODEL: PT-L Energy

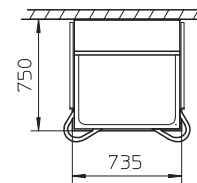
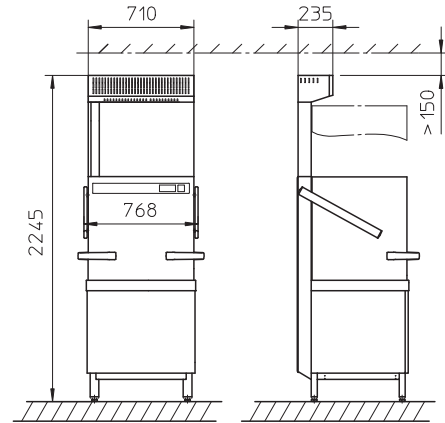

TECHNICAL INFORMATION

Dimensions	735w x 750d x 2245h
Rack Dimension	500 x 600
Clear Entry Height	440
Rinse Water Consumption	2.0L Per Cycle

WATER CONNECTIONS

Connection Point	3/4 inch (19mm)
Inlet Temperature	20c Max
Flow Rate	4 L/Min
Flow Pressure	1.5 bar/Min

ELECTRICAL

3 Phase (Standard)	415v 3P 50Hz - 20amp (TCL 9.7Kw)
3 Phase (Optional)	415v 3P 50Hz - 25amp (TCL 14.2Kw)

GENERAL DATA

Weight (Net/Gross)	165/196Kg
Tank Capacity	35L
Noise Emission	66dB(A)
Cycle Times	50/80/120 Seconds

STANDARD INCLUSIONS

1x 3phase Lead
1x 1m Flexible Water Connection Hose
1x 1m Flexible Waste Hose
2x 500 x 500 Racks (1x Flat, 1x Plate)

STANDARD FEATURES

- Electronic control with colour-coded single button control
- Elliptical wash fields
- Full flow 4 stage wash water filtration
- Clouding sensor
- Active energy management
- Variopower washing pressure adjustment
- Waste water adjustment heat recovery
- Drain pump
- Rinse booster pump
- Chemical pumps
- Energy plus heat recovery (certification to be used without mechanical extraction)